



7415 Diley Road
Canal Winchester, OH 43110

Phone (614) 837-8444
Toll Free (800) 438-2880
Fax (614) 837-1198

MANHOLE STEP

On Target for Quality Precast Concrete Products and Waste Water Treatment Systems

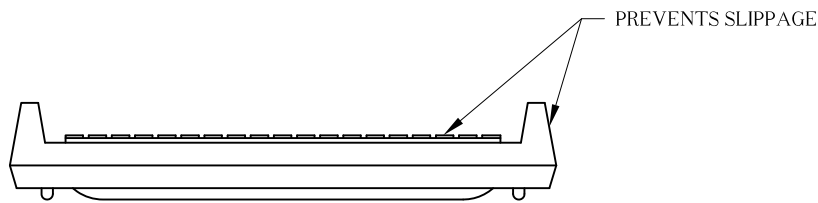
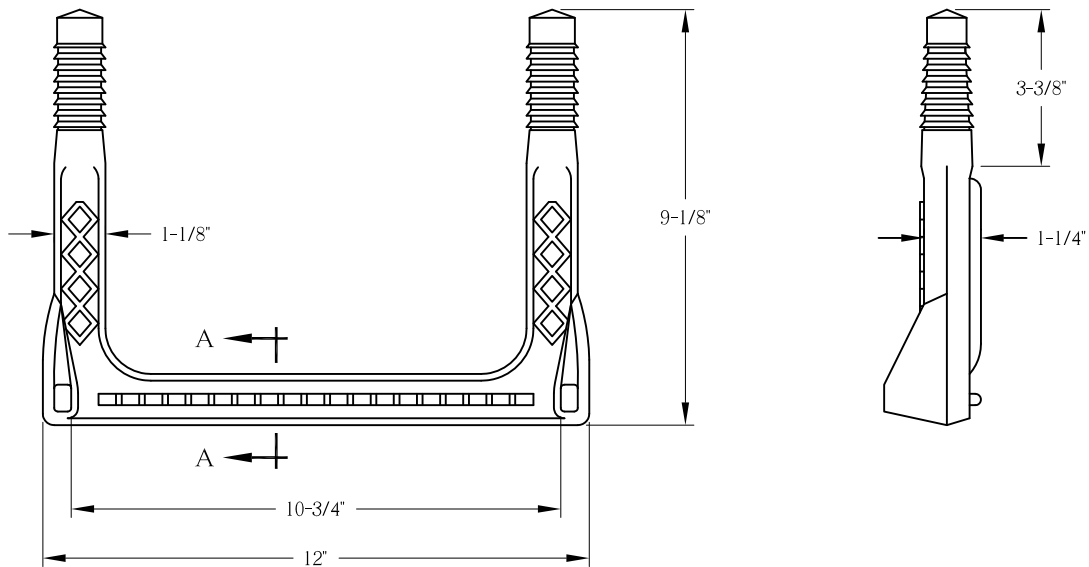

COPOLYMER
POLYPROPYLENE
PLASTIC

1/2" GRADE 60 STEEL
REINFORCEMENT

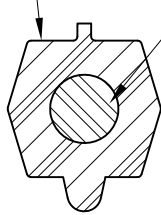

SECTION A-A

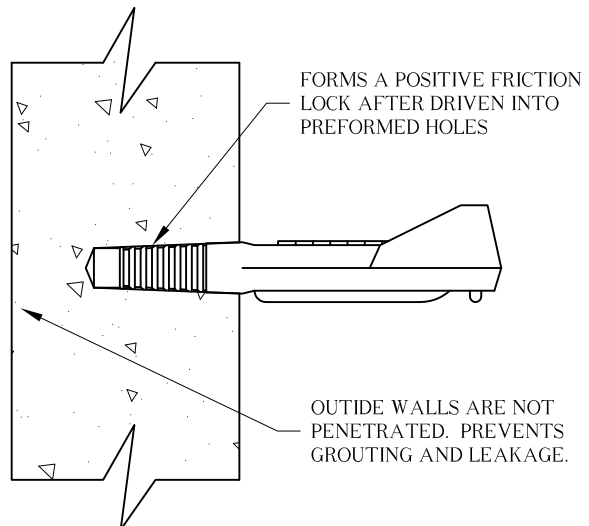

NOTES:

1. Meets ASTM C-478 & ODOT 711.31 specifications.
2. Impact strength-tested up to 300 foot pounds.
3. Pull out strength - resists forces of over 1500 lbs.
4. Durability - superior resistance to all types of corrosive environments found in sewers.