

MODEL 700 ++ Aerator

The Heart of the Jet Residential Plant System

The flood resistant Jet 700++ Aerator supplies the oxygen and the mixing that supports Jet's exclusive treatment process, converting the wastewater into colorless, odorless liquids and gases.

The aerator works in tandem with the BAT® Media to provide complete biological processing.

AERATOR SPECIFICATIONS

Jet Model 700 ++ Aerator	
HP	1/3
RPM	1725
Volt	115
Hz	60
Amps(running)	3.5
Watts(running)	150
Power Factor	0.3
Daily kW/h	3.6
Coolant	Air Cooled
Rotation	Counter Clockwise
Air volume	2.5 CFM avg. 1.8 CFM min.
Circuit Breaker	7 Amp
Shaft Material	Stainless Steel
Shaft Dimensions	27" L, .63" OD, .50 ID
Years of Operation (Est.)	5 - 8

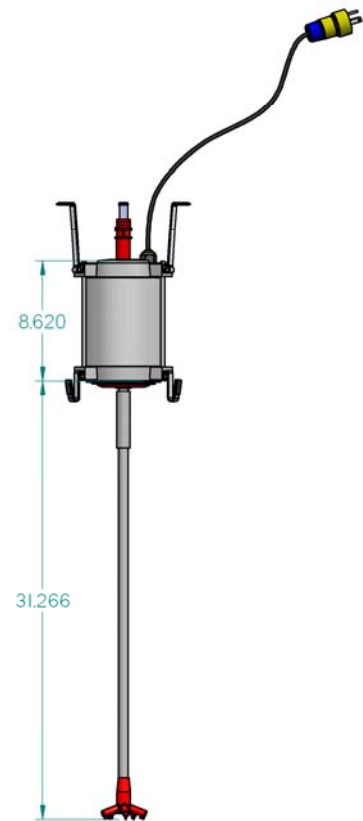

KEY FEATURES

- **Internal Thermal Protection** – Automatic internal Y-breaker protects motor windings from thermal overload
- **Dual Stack Bearings** - Double stacked bearings increase operational life expectancy
- **Double Lip Seals** – Highly efficient dual lip seals increase resistance to water infiltration during flood conditions



750 Alpha Dr. • Cleveland, OH 44143 USA • 440-461-2000 • 1-800-321-6960